

**Features**

- 5mm DIA LED Lamp
- Low Power Consumption
- High Efficiency
- Various Colors and Viewing Angle
- Long Solid State Reliability
- Package: 1000pcs/Packing

**Applications**

- Indicator

**Package Dimensions**

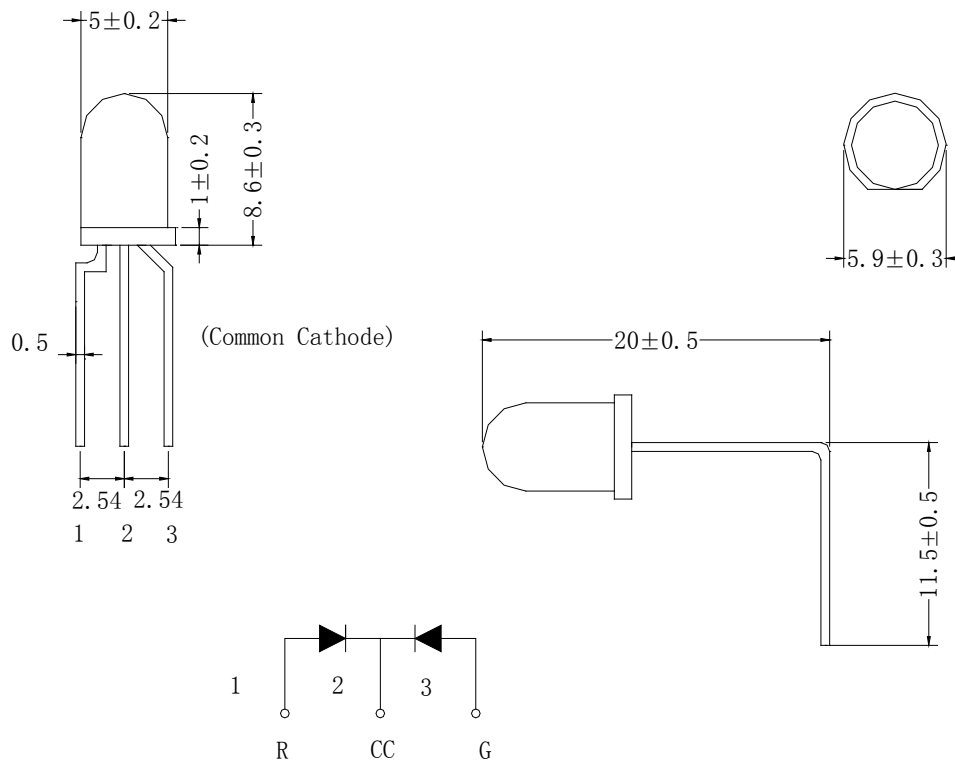

**Notes:**

1. All dimensions are in millimeters (inches).
2. Tolerance is ±0.25mm(.01") unless otherwise noted.
3. Protruded Resin under flange is 1.0mm(0.04") max.
4. Specifications are subject to change without notice.



**Selection Guide**

Part No	Lens Type	Dice	Emitted Color
FDL-5863HRG-TWC1MC-CC-L20-11.5	White Water	GaAsP	Red Green

**Electrical / Optical Characteristics At Ta=25 °C**

Symbol	Parameter		Red	Green	Unit	Test Condition
Iv	Luminous Intensity	TYP.	400	200	mcd	IF=20mA
2θ1/2	Viewing Angle	TYP.	30	30	deg	IF=20mA
λ Peak	Peak Emission Wavelength	TYP.	631	574	nm	IF=20mA
λ d	Dominant Wavelength	TYP.	625	571	nm	IF=20mA
Δλ	Spectral Line Half-Width	TYP.	20	20	nm	IF=20mA
VF	Forward Voltage	TYP.	2.0	2.1	V	IF=20mA
		MAX.	2.5	2.4		
IR	Reverse Current	MAX.	10	10	μ A	VR =5V

Note:

1. θ1/2 is the angle from optical centerline where the luminous intensity is 1/2 optical centerline value

**Absolute Maximum Ratings At Ta=25°C**

Parameter	Green	Super Red	Unit
Power Dissipation	80	80	mW
Peak Forward Current[1]	150	150	mA
Continuous Forward Current	30	30	mA
Reverse Voltage	5	5	V
Operating Temperature Range	-45°C to + 85°C		
Storage Temperature Range	-55°C to + 105°C		
Soldering Condition	260°C For 10 Seconds		

Note:

1. 1/10DutyCycle, 0.1ms Pulse Width

**Electrical Optical Characteristics Curves At Ta=25 °C**

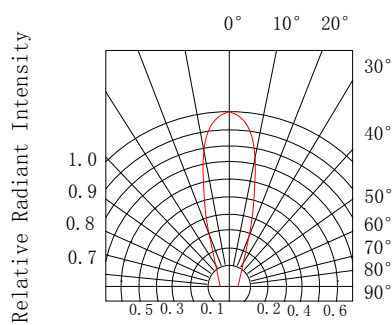
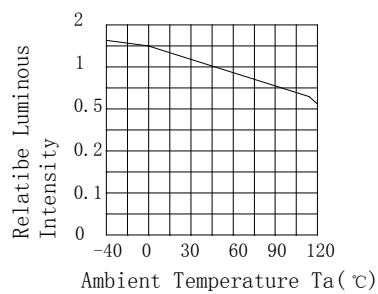
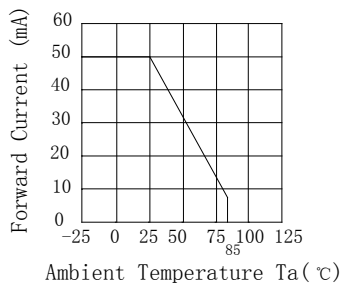
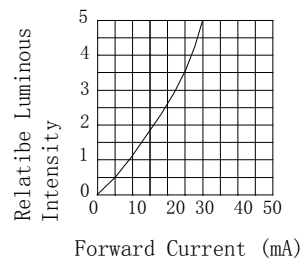
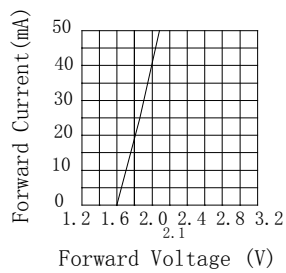
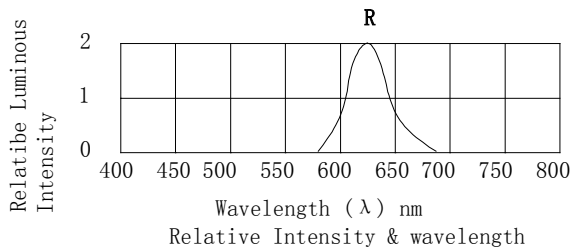

Radiation Diagram

**Electrical Optical Characteristics Curves At Ta=25 °C**

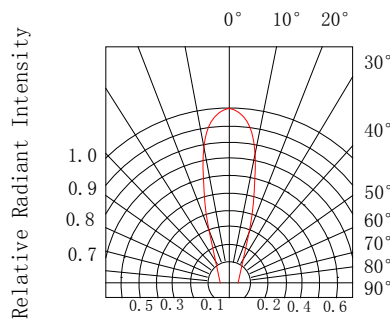
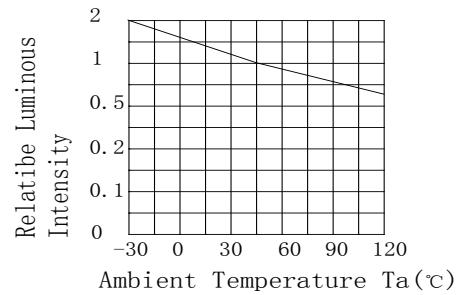
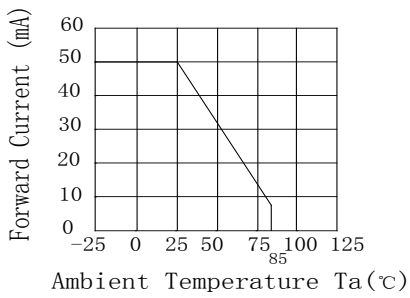
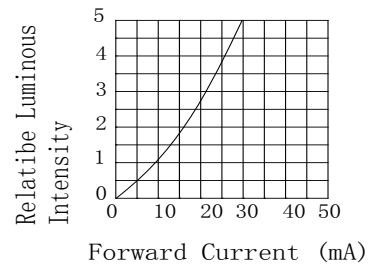
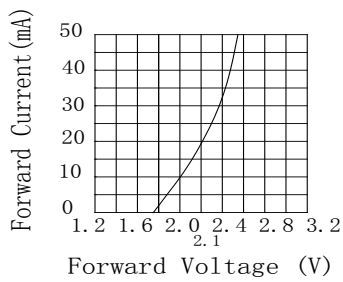
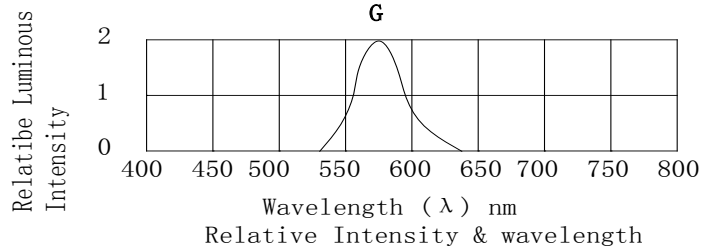

Radiation Diagram

**Notes:**

1. The LEDs should be used within a year.
2. The LEDs should be kept in 5~30°C and 60% RH for less.
3. The LEDs should be used within 24 hours, or else should be kept a 5~30°C and 30% RH or less. And LEDs should be used within 7 days after opening the package.

**Reliability Test Items Conditions**

Classification	Test Item	Test Conditions	Test hours	Result
Endurance Test	Opertion Life	Connect with a power if=20mA Ta=Under room temperature	1000Hrs	0/20
	Hige Temperature High Humidity	Ta=+65°C±5°C RH=90%-95%	240Hrs	0/20
	Hige Temperature Storage	High Ta=+85°C±5°C	1000Hrs	0/20
	Low Temperature Storage	Low Ta=-35°C±5°C Test time=1000hrs	1000Hrs	0/20
Environmental Test	Temperature Cycling	-45°C ~+105°C 15min 5min 15min	300 Cycles	0/20
	Thermal Shock	-35°C ~±5°C ~+85°C ~±5°C 5min 10sec 5min	300 Cycles	0/20
	Solder Resistance	Preheating: 120°C-150°C,within 2 minutes. Operation heating : 260°C (Max.),within5 seconds(Max.)	5Cycles	0/20

**Judgment criteria of fialure for the reliability**

Measuring items	Symbol	Measuring conditions	Judement criteria for failure
Forward voltage	V <sub>F</sub> (V)	I <sub>F</sub> =20mA	Over U×1.2
Rvevrse current	I <sub>R</sub> (μA)	V <sub>R</sub> =5V	Over U×2
Luminous intensity	I <sub>v</sub> (mcd)	I <sub>F</sub> =20mA	Below S×0.5

Note: 1.U means the upper limit of specified characteristics. S means initial value.

2.Meansurment shall be taken between 2 hours after the test pieces have been returnde to normal ambient cnditions after completion of each test.